

# I-Meet

Nikolas Chachamis - CSR Las Mobili



## La collezione si caratterizza per:

**01/** Gambe in acciaio cromato lucido o verniciate nero opaco. **02/** Postazione relatore a cattedra singola e doppia. **03/** Leggio. **04/** Contromobile con basamento metallico. **05/** Modulo top access elettrificato e non con apertura basculante. **06/** Wire manager sottopiano. **07/** 4 finiture di legni e 2 tinte unite per i piani. **08/** 1 finitura in vetro.

## This collection is characterised by:

**01/** Polished chrome-finished steel legs or matt black painted legs. **02/** Speakers' place with single or double desk. **03/** Podium. **04/** Matching furniture with metal base. **05/** Wired and non-wired top access module with tilting opening. **06/** Under-the-top wire manager. **07/** 4 wood finishes and 2 plain colours for the worktops. **08/** 1 glass finish.

## La collection est caractérisée par :

**01/** Pieds en acier chromés polis ou peints en noir mat. **02/** Poste de l'orateur à table single ou double. **03/** Pupitre. **04/** Contre-meuble avec base en métal. **05/** Module top-access électrifié ou non électrifié avec ouverture basculante. **06/** Système de gestion des câbles sous le plateau. **07/** 4 finitions en bois et 2 couleurs pleins pour les plateaux. **08/** 1 finition en verre.







cod. 12



cod. NR 03



↑  
Tavolo riunioni  
in formato  
quadrato con top  
access centrale.

Square meeting  
table with  
central top  
access.

Table de réunion  
carré avec top  
access central.

**Tavoli riunioni in vari formati, variamente aggregabili fino alle grandi composizioni. La riduzione degli appoggi e la sezione snella delle gambe conferiscono grande leggerezza e stabilità ad ogni composizione, permettendo un perfetto utilizzo su ogni lato.**

Tables de réunion dans formats différents, qui peuvent être combinées pour obtenir de grandes compositions. La réduction des appuis et la section élancée des pieds donne une grande légèreté et stabilité aux compositions, pour une utilisation parfaite sur tous les côtés.

Meeting tables in different formats that can be combined in a number of ways up to large compositions. The reduction of supporting elements and the slender legs add lightness and stability to each composition, allowing perfect use on all sides.

cod. 56





cod. 30

→  
L'angolo è  
caratterizzato  
dallo smusso che  
segue la posizione  
della gamba.  
Corners are  
characterised  
by the bevelling  
that mirrors the  
leg position.  
Le coin est  
caractérisé par  
le biseau qui suit  
la position de  
la jambe.



**Nelle grandi composizioni è assicurato un ottimale cablaggio in ogni posizione, grazie a top access lineari e ampi Wire Manager per le salite.**

In large compositions, optimal wiring is available in all positions, thanks to linear top access openings and large Wire Managers for upward wiring.

Dans les grandes compositions, le câblage optimal est assuré dans n'importe quelle position, grâce au top access linéaire et aux amples systèmes Wire Managers pour les montées des câbles.

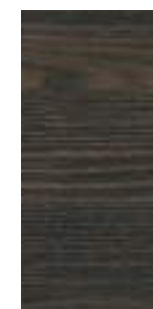

cod. 52







→  
 Il cablaggio  
 è facilmente  
 accessibile e  
 perfettamente  
 nascosto.  
 Wiring is easily  
 accessible  
 and completely  
 hidden.  
 Le câblage est  
 facilement  
 accessible et  
 parfaitement  
 caché.



cod.NR 03    cod.12

**In ambienti conferenza o formazione la postazione dei relatori assume un valore comunicativo e tecnico ineccepibile. Il livello estetico è adeguato alla qualità dell'ambiente, le dotazioni tecnologiche soddisfano le funzioni specifiche di una relazione in presenza o online.**

Dans les salles de conférence ou de formation, la position des intervenants acquiert une valeur communicative et technique impeccable. Le niveau esthétique est conforme à la qualité de l'environnement, les équipements technologiques répondent aux fonctions spécifiques des relation en face à face ou en ligne.

In conference or training environments, the speakers' seat features an impeccable communicative and technical value. The aesthetic level is up to the quality of the environment, with technological equipment that meet specific functions of both face-to-face and online relationships.







< L'angolo smussato mantiene lo stesso allineamento della gamba.  
Bevelled corners maintain the alignment with the legs.  
Le coin arrondi maintient le même alignement du pied.

**I piani di lavoro in cristallo retro laccato conferiscono grande eleganza al tavolo riunioni e si pongono in contrapposizione col modulo tecnologico centrale in legno. Un ulteriore livello di pregio di materiali ed abbinamenti per un meeting moderno ed elegante.**

Back-lacquered glass worktops give great elegance to the meeting table and create contrast with the wood of the central technical module. An additional level of quality in materials and combinations, for modern and elegant meetings.

> Tavolo riunioni quadrato con modulo tecnico centrale.  
Square meeting table with technical central module.  
Table de réunion carré avec module technique central.

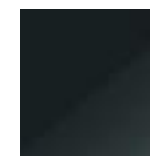

cod. 10

Les plans de travail en verre rétro-laqué donnent une grande élégance à la table de réunion et contrastent avec le module technologique central en bois. Un ultime niveau de prestige dans les matériels et les combinaisons pour des rencontres modernes et élégantes.





**Tavoli riunione**

Meeting tables | Tables de réunion

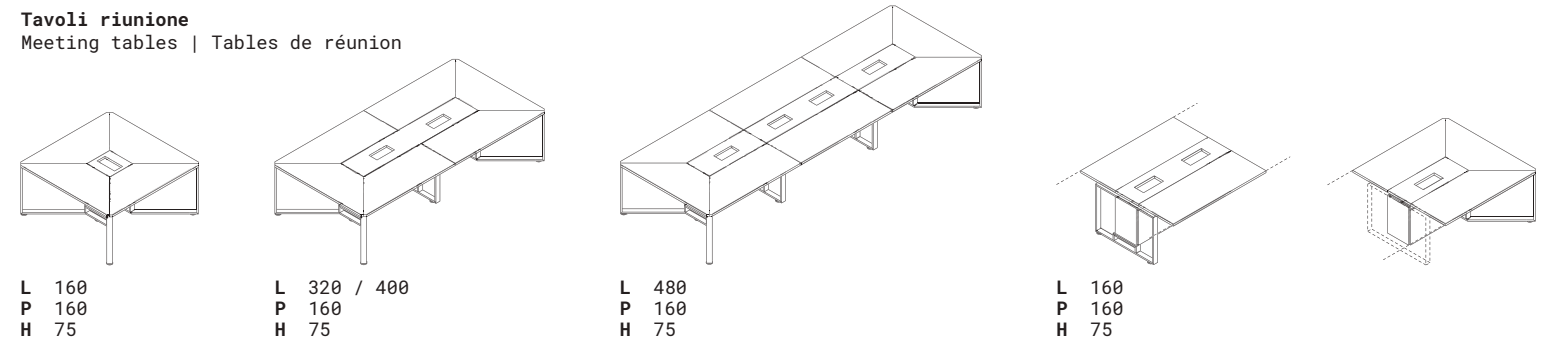

L 160  
P 160  
H 75

L 320 / 400  
P 160  
H 75

L 480  
P 160  
H 75

L 160  
P 160  
H 75

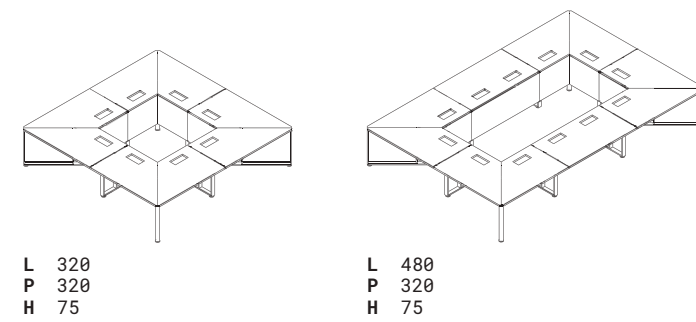

L 320  
P 320  
H 75

L 480  
P 320  
H 75

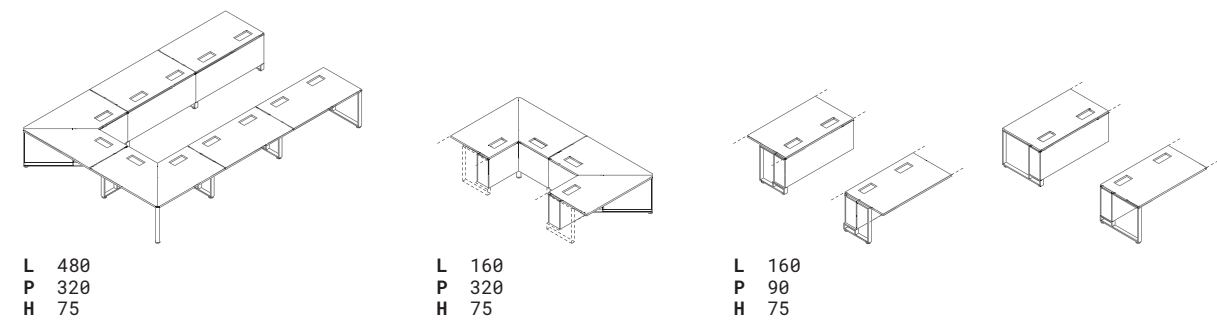

L 480  
P 320  
H 75

L 160  
P 320  
H 75

L 160  
P 90  
H 75

**Complementi di arredo**

Accessories | Meubles de rangements

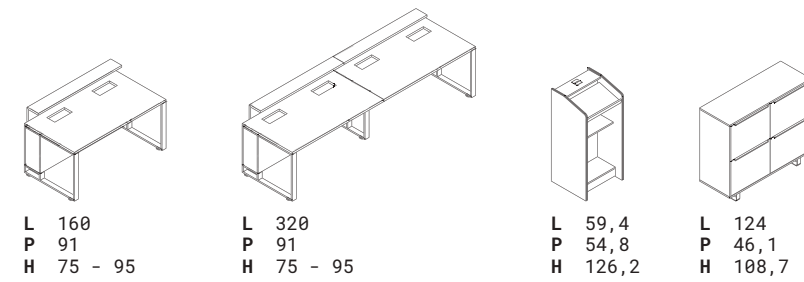

L 160  
P 91  
H 75 - 95

L 320  
P 91  
H 75 - 95

L 59,4  
P 54,8  
H 126,2

L 124  
P 46,1  
H 108,7